

ARIO Series

Slim Remote I/O

■ Features

- I/O supported based on industrial Ethernet / Fieldbus serial communication for Smart Factory
- Sequential multiple I/O distribution control via PLC, Industrial PC, etc.
- Coupler: Supports a total of 8 different communications
EtherCAT, CC-Link, ProfiNet, ProfiBus, Ethernet/IP, DeviceNet, Modbus TCP compatible, Modbus RTU compatible
- Modules: Various Input / Output Modules, Power Modules
 - Remote ABUS/ I/O power, Digital input/output (4/8CH), Analog input/output (2/4CH), Temperature input (4CH)
 - Up to 64 modules can be extended (depending on communication)
- Hot-swap function
 - : Maintenance and setting can be restored automatically by replacing terminal and body during operation
- Push-in connection method: Easy wire connection without tools helps reducing workload
- Expanded user convenience with DAQMaster, a device integration management program
 - Module setting, real time control and monitoring / diagnosis of input / output signal (except ARIO-C-PN/PB)
 - Product selection and placement through virtual mode, offering recommended sorting



⚠ Please read "Safety Considerations" in the instruction manual before using.



■ Models

● Coupler

| Model | ARIO-C-EC | ARIO-C-CL | ARIO-C-PN | ARIO-C-PB | ARIO-C-EI | ARIO-C-DN | ARIO-C-MT | ARIO-C-MR |
|--------------|-----------|-----------|-----------|-----------|-------------|-----------|----------------------|----------------------|
| Coupler type | EtherCAT | CC-Link | ProfiNet | Profibus | Ethernet/IP | DeviceNet | ModbusTCP compatible | ModbusRTU compatible |

● Digital Input/Output Module

| Type | Digital input module | | | | Digital output module | | | | | | |
|------------|----------------------|--------------|--------------|--------------|-----------------------|-------|------|-----------------|-----------------|-----------------|-----------------|
| Model | 4CH | ARIO-S-DI04N | ARIO-S-DI04P | ARIO-S-DO04N | ARIO-S-DO04P | Model | 2 CH | ARIO-S-AI02V1/2 | ARIO-S-AI02C1/2 | ARIO-S-AO02V1/2 | ARIO-S-AO02C1/2 |
| | 8CH | ARIO-S-DI08N | ARIO-S-DI08P | ARIO-S-DO08N | ARIO-S-DO08P | | 4 CH | ARIO-S-AI04V1/2 | ARIO-S-AI04C1/2 | ARIO-S-AO04V1/2 | ARIO-S-AO04C1/2 |
| I/O common | NPN | PNP | NPN | PNP | | | | | | | |

● Analog Input/Output Module

| Type | Analog input module | | | | Analog output module | | | | | | |
|------------|---------------------|-----------------|-----------------|-----------------|----------------------|-------|------|-----------------|-----------------|-----------------|-----------------|
| Model | 2 CH | ARIO-S-AI02V1/2 | ARIO-S-AI02C1/2 | ARIO-S-AO02V1/2 | ARIO-S-AO02C1/2 | Model | 2 CH | ARIO-S-AI02V1/2 | ARIO-S-AI02C1/2 | ARIO-S-AO02V1/2 | ARIO-S-AO02C1/2 |
| | 4 CH | ARIO-S-AI04V1/2 | ARIO-S-AI04C1/2 | ARIO-S-AO04V1/2 | ARIO-S-AO04C1/2 | | 4 CH | ARIO-S-AI04V1/2 | ARIO-S-AI04C1/2 | ARIO-S-AO04V1/2 | ARIO-S-AO04C1/2 |
| I/O method | Voltage input | Current input | Voltage output | Current output | | | | | | | |

● Power Module

| Model | ARIO-P-B | ARIO-P-F1 | ARIO-P-F2 | ARIO-P-T1 | ARIO-P-T2 |
|----------------------|------------------------|-----------------------|-----------|-----------|-----------|
| Power module | Slim Remote ABUS power | Slim Remote I/O power | | | |
| No. I/O supply power | 24V 0V | 6 2 | 2 6 | 8 4 | 4 8 |

● Temperature Input Module

| Type | TC input module | | RTD input module | |
|--------------|-----------------|---------------|------------------|--|
| Model | 4CH | ARIO-S-AI04TC | ARIO-S-AI04RTD | |
| Input method | Voltage input | | Resistance input | |

※ Coupler: You can order each the terminal and base.
Module: You can order each the terminal, body, and base.

■ Comprehensive Device Management Program (DAQMaster)

- DAQMaster is comprehensive device management program. It is available for parameter setting, monitoring.
- Visit our website (www.autonics.com) to download user manual and comprehensive device management program.

< Computer specification for using software >

| Item | Minimum requirements |
|------------------|--|
| System | IBM PC compatible computer with Intel Pentium III or above |
| Operating system | Microsoft Windows 98/NT/XP/Vista/7/8/10 |
| Memory | 256MB or more |
| Hard disk | More than 1GB of free hard disk space |
| VGA | 1024×768 or higher resolution display |
| Others | RS-232 serial port (9-pin), USB port |

< DAQMaster screen >

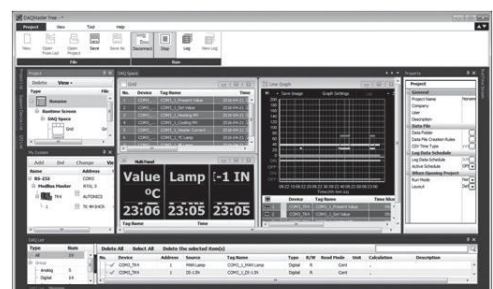

Manuals

1. Instruction manual

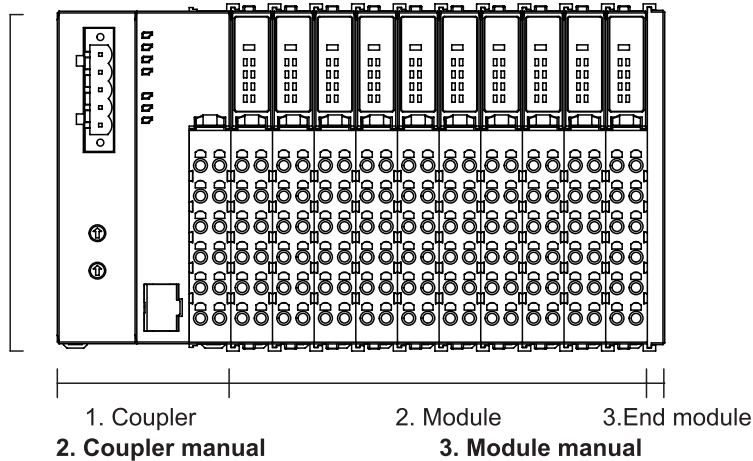

1. Instruction manual

It describes an overview of Remote I/O, definitions of terms, installation environment, routing/ removing method, wiring and troubleshooting.

2. Coupler manual



It describes the overview, specification, dimensions, memory map and troubleshooting of each communication.

3. Module manual

It describes the specification, dimensions, and connections of each module.

Coupler

Specifications

| Model | ARIO-C-EC | ARIO-C-CL | ARIO-C-PN | ARIO-C-PB | ARIO-C-EI | ARIO-C-DN | ARIO-C-MT | ARIO-C-MR | |
|--------------------------------|---|--|--------------------|-----------------------|--------------------|---------------------|----------------------|----------------------|----------|
| Coupler type | EtherCAT | CC-Link | ProfiNet | ProfiBus | Ethernet/IP | DeviceNet | ModbusTCP compatible | ModbusRTU compatible | |
| Power supply ※1 | ABUS (external consump.) | 24VDC=, max. 400mA (max. 9.6W, coupler+module, max. 200mA/CH, 2CH/COM) | | | | | | | |
| | ABUS (internal supply) | 5VDC=, max. 960mA (max. 4.8W, module) | | | | | | | |
| | I/O | 24VDC=, max. 4,000mA (max. 96W, max. 2,000mA/CH, 2CH/COM) | | | | | | | |
| Power consumption | Coupler 24VDC= standby/run: 200mA, max. load: 400mA (coupler max. load) | | | | | | | | |
| Comm. speed | 100Mbps | 10Mbps | 100Mbps | 12Mbps | 10/100Mbps | 500kbps | 10/100Mbps | 115.2kbps | |
| Memory※2 | Input | 512 byte | 256 byte | 512 byte | 244 byte | 504 byte | 255 byte | 512 byte | 256 byte |
| | Output | 512 byte | 256 byte | 512 byte | 244 byte | 504 byte | 255 byte | 512 byte | 256 byte |
| Max. connections for modules※2 | 64 units | 32 units | 64 units | 32 units | 64 units | 32 units | 64 units | 32 units | |
| Comm. connector | RJ45 connectors: 2 | 5-pin PCB connector | RJ45 connectors: 2 | 9-pin D SUB connector | RJ45 connectors: 2 | 5-pin PCB connector | RJ45 connectors: 2 | 5-pin PCB connector | |
| Installation method | DIN rail mounting | | | | | | | | |
| Setting and monitoring | PC connection with USB 2.0 Micro type connector (comprehensive device management program, DAQMaster) | | | | | | | | |
| Insulation resistance | Over 100MΩ (at 500VDC= megger) | | | | | | | | |
| Environ-ment | Ambient temp. | -10 to 55°C, storage: -25 to 70°C | | | | | | | |
| | Ambient humi. | 35 to 85%RH, storage: 35 to 85%RH | | | | | | | |
| Protection structure | IP20 (IEC standards) | | | | | | | | |
| Material | Terminal: polyamide6, Body: modified polyphenylene oxide, Base: polyamide6, polyoxymethylene | | | | | | | | |
| Approval |   | | | | | | | | |
| Weight※3 | Approx. 265g (approx. 165g) | | | | | | | | |

※1. It is for including power/special modules and excluding coupler/end modules. In case of one coupler module connecting, the ARIO digital module is available to connect up to 8 units and the ARIO analog module is available to connect up to 4 units. For connecting the modules, consider power consumption of the sensors and drivers connected the ARIO coupler.

※2. If it is over the limit size or connected units, system may be error.

※3. The weight includes packaging. The weight in parenthesis is for unit only.

※Environment resistance is rated at no freezing or condensation.

SENSORS

CONTROLLERS

MOTION DEVICES

SOFTWARE

(J) Temperature Controllers

(K) SSRs

(L) Power Controllers

(M) Counters

(N) Timers

(O) Digital Panel Meters

(P) Indicators

(Q) Converters

(R) Digital Display Units

(S) Sensor Controllers

(T) Switching Mode Power Supplies

(U) Recorders

(V) HMIs

(W) Panel PC

(X) Field Network Devices

ARIO Series

■ Dimensions

(Unit: mm)

● Coupler

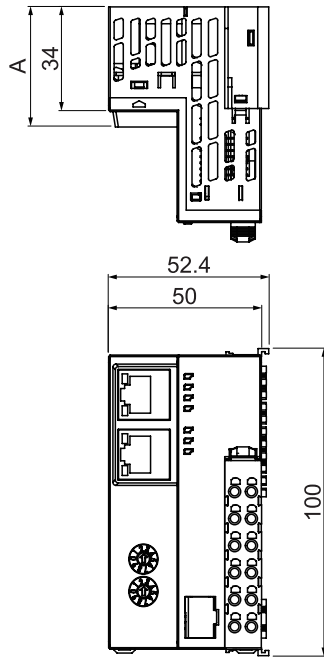

| Model | A size |
|--------------------|--------|
| ARIO-C-EC/EI/PN/MT | 39 |
| ARIO-C-DN/CL/MR | 36.2 |
| ARIO-C-PB | 38.2 |

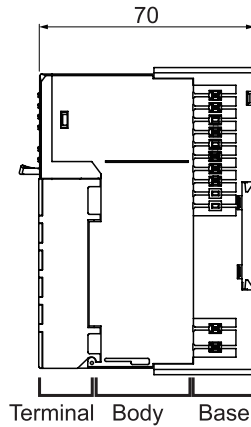

● End module

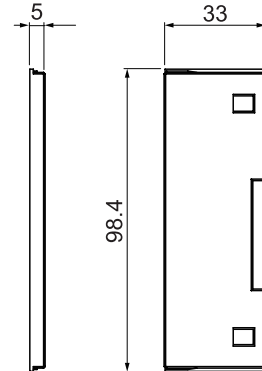

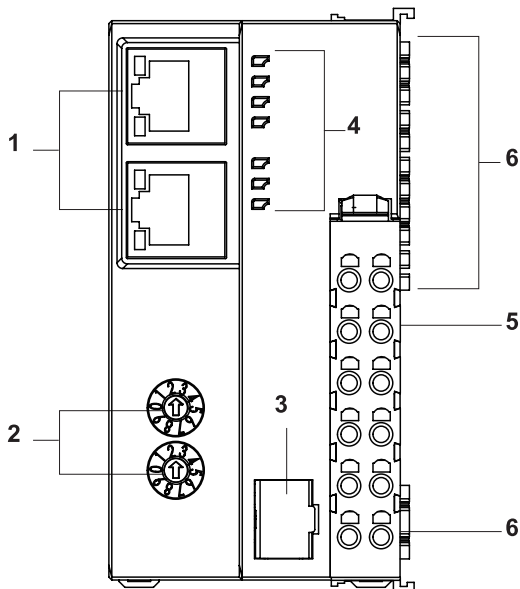

■ Unit Description

※ It may be different depending on the coupler model.



1. Communication connector

| ARIO-C-EC/PN/EI/MT | ARIO-C-PB | ARIO-C-CL/DN/MR |
|---|---|---|
| RJ-45: 2 | DSUB-9Pin | 5-Pin PCB connector |
|  |  |  |

2. Communication setting switch

| ARIO-C-EC | ARIO-C-CL/DN | The others |
|-----------|--|---|
| None | Decimal rotary switches: 3 (Comm. speed, address (×10, ×1)) | Hexagonal rotary switches: 2 (address (×10, ×1)) |

3. Setting connector (USB 2.0 type Micro B)





4. Indicators for power and comm. status

5. Power terminal block

6. ABUS comm. connector

Digital Input/Output Module

Specifications

| Type | | Digital input module | | Digital output module | |
|--------------------------------|---------------|---|---------------------|------------------------|---------------------|
| Model | 4CH | ARIO-S-DI04N | ARIO-S-DI04P | ARIO-S-DO04N | ARIO-S-DO04P |
| | 8CH | ARIO-S-DI08N | ARIO-S-DI08P | ARIO-S-DO08N | ARIO-S-DO08P |
| I/O common | | NPN | PNP | NPN | PNP |
| Input voltage | | Turn ON: min. 7VDC≒ Turn OFF: max. 0.4VDC≒ | | — | |
| Output leakage voltage | | — | | Max. 1.2VDC≒ | |
| I/O signal level ^{※1} | | 24VDC≒±10% | | | |
| I/O current consumption | 4CH | Max. 6mA/CH, 4CH/COM | | — | |
| | 8CH | Max. 6mA/CH, 8CH/COM | | — | |
| Rated output current | 4CH | — | | Max. 500mA/CH, 4CH/COM | |
| | 8CH | — | | Max. 500mA/CH, 8CH/COM | |
| On delay time | | Max. 0.5ms | | | |
| Off delay time | | Max. 1.5ms | | | |
| Power consump. (ABUS) | | 5VDC≒, max. 100mA (max. 0.5W) | | | |
| Installation method | | DIN rail mounting | | | |
| Insulation resistance | | 100MΩ (at 500VDC≒ megger) I/O to inner circuit: photocoupler insulated, between CHs: non-insulated | | | |
| Environment | Ambient temp. | 10 to 55°C, storage: -25 to 70°C | | | |
| | Ambient humi. | 35 to 85%RH, storage: 35 to 85%RH | | | |
| Protection structure | | IP20 (IEC standard) | | | |
| Material | | Terminal: polyamide6, Body: modified polyphenylene oxide, Base: polyamide6, polyoxymethylene | | | |
| Approval | |     | | | |
| Weight ^{※2} | | Approx. 108g (approx. 75g) | | | |

※1. Power supply is from I/O power of coupler or ARIO-P-F Series. Normal operation is available when I/O power voltage is supplied.

※2. The weight includes packaging. The weight in parenthesis is for unit only.

※Environment resistance is rated at no freezing or condensation.

※In case of one coupler module connecting, the ARIO digital module is available to connect up to 8 units. For connecting the modules, consider power consumption of the sensors and drivers connected the ARIO coupler.

Dimensions

(Unit: mm)

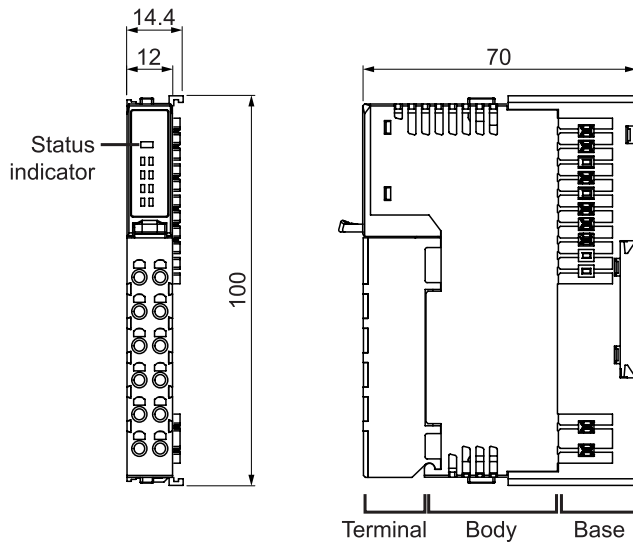

SENSORS

CONTROLLERS

MOTION DEVICES

SOFTWARE

(J)
Temperature
Controllers

(K)
SSRs

(L)
Power
Controllers

(M)
Counters

(N)
Timers

(O)
Digital
Panel Meters

(P)
Indicators

(Q)
Converters

(R)
Digital
Display Units

(S)
Sensor
Controllers

(T)
Switching
Mode Power
Supplies

(U)
Recorders

(V)
HMI's

(W)
Panel PC



(X)
Field Network
Devices

Analog Input/Output Module

■ Specifications

| | | | | | |
|--------------------------------|--|----------------------|----------------------|----------------------|----------------------|
| Type | Analog input module | | | | |
| Model | 2CH | ARIO-S-AI02V1 | ARIO-S-AI02V2 | ARIO-S-AI02C1 | ARIO-S-AI02C2 |
| | 4CH | ARIO-S-AI04V1 | ARIO-S-AI04V2 | ARIO-S-AI04C1 | ARIO-S-AI04C2 |
| Input method | Voltage input | | | Current output | |
| Input range | -10 to 10VDC \equiv | | 0 to 10VDC \equiv | 0 to 20mA | 4 to 20mA |
| Accuracy | Room temp.: $\pm 0.3\%$ F.S. / Out of room temp.: $\pm 0.6\%$ F.S. | | | | |
| Input impedance | Min. 1M Ω / Max. 250 Ω | | | | |
| Status indicator ON conditions | Below -1V or over 1V | Over 1V | Over 1mA | Over 4mA | |
| Resolution | 12bit | | | | |
| Power consumption | ABUS: 5VDC \equiv , max. 180mA (max. 0.9W), I/O: 24VDC \equiv , max. 15mA (max. 0.36W) | | | | |

| | | | | | |
|--------------------------------|--|----------------------|----------------------|--|----------------------|
| Type | Analog output module | | | | |
| Model | 2CH | ARIO-S-AO02V1 | ARIO-S-AO02V2 | ARIO-S-AO02C1 | ARIO-S-AO02C2 |
| | 4CH | ARIO-S-AO04V1 | ARIO-S-AO04V2 | ARIO-S-AO04C1 | ARIO-S-AO04C2 |
| Output method | Voltage output | | | Current output | |
| Output range | -10 to 10VDC \equiv | | 0 to 10VDC \equiv | 0 to 20mA | 4 to 20mA |
| Accuracy | Room temp.: $\pm 0.3\%$ F.S. / Out of room temp.: $\pm 0.6\%$ F.S. | | | | |
| Load resistance | Min. 5k Ω / Max. 350 Ω | | | | |
| Status indicator ON conditions | Below -1V or over 1V | Over 1V | Over 1mA | Always ON | |
| Resolution | 12bit | | | | |
| Power consumption | ABUS: 5VDC \equiv , max. 180mA (max. 0.9W), I/O: 24VDC \equiv , max. 15mA (max. 0.36W) | | | ABUS: 5VDC \equiv , max. 100mA (max. 0.5W), I/O: 24VDC \equiv , max. 60mA (max. 1.44W) | |

| | | | | | |
|-----------------------|---|-----------------------------------|--|--|--|
| Installation method | DIN rail mounting | | | | |
| Insulation resistance | 100M Ω (at 500VDC \equiv megger) I/O to inner circuit: photocoupler insulated, between channels: non-insulated | | | | |
| Environment | Ambient temp. | -10 to 55°C, storage: -25 to 70°C | | | |
| | Ambient humi. | 35 to 85%RH, storage: 35 to 85%RH | | | |
| Protection structure | IP20 (IEC standard) | | | | |
| Material | Terminal: polyamide6, Body: modified polyphenylene oxide, Base: polyamide6, polyoxymethylene | | | | |
| Approval |   | | | | |
| Weight ^{*1} | Approx. 108g (approx. 75g) | | | | |

※1. The weight includes packaging. The weight in parenthesis is for unit only.

※Environment resistance is rated at no freezing or condensation.

※Power supply is from I/O power of coupler or ARIO-P-F Series. Normal operation is available when I/O power voltage is supplied. In case of one coupler module connecting, the ARIO analog module is available to connect up to 4 units. For connecting the modules, consider power consumption of the sensors and drivers connected the ARIO coupler.

■ Dimensions

(Unit: mm)

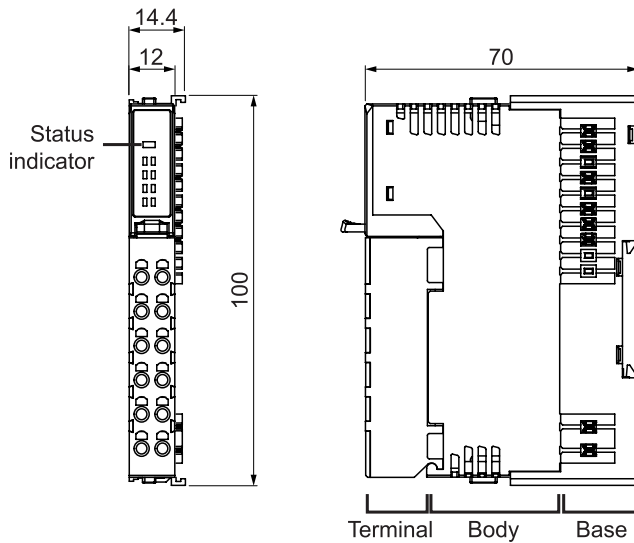

| |
|----------------|
| SENSORS |
| CONTROLLERS |
| MOTION DEVICES |
| SOFTWARE |

| |
|-----------------------------------|
| (J) Temperature Controllers |
| (K) SSRs |
| (L) Power Controllers |
| (M) Counters |
| (N) Timers |
| (O) Digital Panel Meters |
| (P) Indicators |
| (Q) Converters |
| (R) Digital Display Units |
| (S) Sensor Controllers |
| (T) Switching Mode Power Supplies |
| (U) Recorders |
| (V) HMIs |
| (W) Panel PC |
| (X) Field Network Devices |

Temperature Input Module

■ Specifications

| | | |
|--------------------------------|--|-----------------------------------|
| Type | Temperature input module | |
| Model | 4CH | ARIO-S-AI04TC ARIO-S-AI04RTD |
| Input method | Voltage input | Resistance input |
| Display accuracy*1 | ±0.2% F.S.(or ±2°C, select higher one) ±1 digit | ±0.2% F.S.±1 digit |
| Status indicator ON conditions | Temperature input within the rated range ※ No operation when the thermometer is not attached. | |
| Resolution / Display | 16bit / 0.1°C | |
| Power consumption | ABUS: 5VDC=, max. 180mA w(max. 0.9W), I/O: 24VDC=, max. 15mA (max. 0.36W) | |
| Installation method | DIN rail mounting | |
| Insulation resistance | 100MΩ (at 500VDC= megger) I/O to inner circuit: photocoupler insulated, between channels: non-insulated | |
| Environment | Ambient temp. | -10 to 55°C, storage: -25 to 70°C |
| | Ambient humi. | 35 to 85%RH, storage: 35 to 85%RH |
| Protection structure | IP20 (IEC standard) | |
| Material | Terminal: polyamide6, Body: modified polyphenylene oxide, Base: polyamide6, polyoxymethylene | |
| Approval | CE cULUS LISTED | |
| Weight*2 | Approx. 108g (approx. 75g) | |

※1. Ⓒ At room temperature (23°C ± 5°C)

- Below -100°C of TC K, J, T, N, E and TC L, U, PLII: ±4°C ±1 digit
- Below ±200°C of TC R, S: ±4°C ±1 digit
- Below 400°C of TC B: No display accuracy
- RTD Cu 50 Ω / 100 Ω, Ni 100 Ω / 120 Ω / 1000 Ω: ±2°C ±1digit

Ⓒ Out of room temperature range

- TC: (±0.5% F.S or ±7°C, select the higher one) ± 1digit
- RTD: (±0.5% F.S or ±3°C, select the higher one) ±1digit

※2. The weight includes packaging. The weight in parenthesis is for unit only.

※Environment resistance is rated at no freezing or condensation.

※Power supply is from I/O power of coupler or ARIO-P-F Series. Normal operation is available when I/O power voltage is supplied.

In case of one coupler module connecting, the ARIO analog module is available to connect up to 4 units. For connecting the modules, consider power consumption of the sensors and drivers connected the ARIO coupler.

ARIO Series

Input type and range

| Input type | | Rated input range (°C) | Data display (dec) |
|-------------------|---------------------|------------------------|--------------------|
| Thermocouple (TC) | K(CA) | -200.0 to 1350.0 | -2000 to 13500 |
| | J(IC) | -200.0 to 800.0 | -2000 to 8000 |
| | E(CR) | | |
| | T(CC) | -200.0 to 400.0 | -2000 to 4000 |
| | B(PR) | 0.0 to 1800.0 | 0 to 18000 |
| | R(PR) | 0.0 to 1750.0 | 0 to 17500 |
| | S(PR) | | |
| | N(NN) | -200.0 to 1300.0 | -2000 to 13000 |
| | C(TT) ^{※1} | 0.0 to 2300.0 | 0 to 23000 |
| | G(TT) ^{※2} | | |
| | L(IC) | -200.0 to 900.0 | -2000 to 9000 |
| | U(CC) | -200.0 to 400.0 | -2000 to 4000 |
| | Platine I II | 0.0 to 1390.0 | 0 to 13900 |
| RTD | Cu 50Ω | -200.0 to 200.0 | -2000 to 2000 |
| | Cu 100Ω | | |
| | DPt 50Ω | -200.0 to 650.0 | -2000 to 6500 |
| | DPt 100Ω | | |
| | DPt 1000Ω | -200.0 to 500.0 | -2000 to 5000 |
| | JPt 50Ω | -200.0 to 650.0 | -2000 to 6500 |
| | JPt 100Ω | | |
| | JPt 1000Ω | -200.0 to 500.0 | -2000 to 5000 |
| | Nickel 100Ω | -50.0 to 200.0 | -500 to 2000 |
| | Nickel 120Ω | | |
| | Nickel 1000Ω | | |

※ 1. Same as existing W5(TT).

※ 2. Same as existing W(TT).

Dimensions

(Unit: mm)

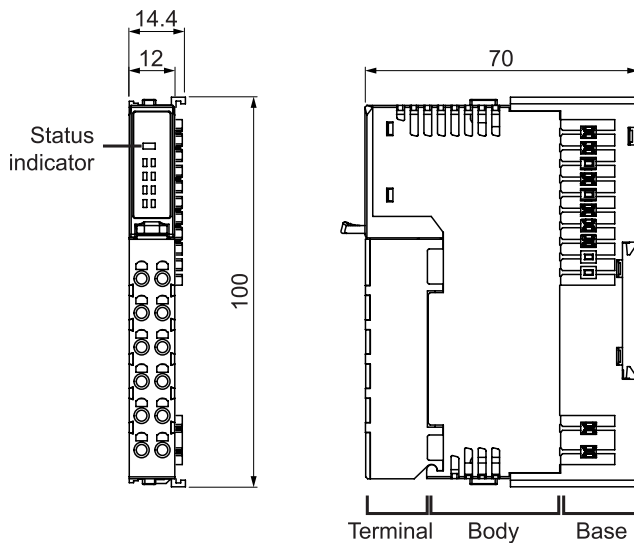

Power Module

■ Specifications

● Slim Remote ABUS Power Module

| | | |
|-----------------------|--|---|
| Model | ARIO-P-B | |
| Power supply | ABUS (external consumption) | 24VDC \pm %, max. 320mA (max. 7.5W, max. 160mA/CH, 2CH/COM) |
| | ABUS (internal supply) | 5VDC \pm %, max. 1,500mA (max. 7.5W) |
| Installation method | DIN rail mounting | |
| Insulation resistance | 100M Ω (at 500VDC \pm megger) | |
| Environment | Ambient temp. | -10 to 55°C, storage: -25 to 70°C |
| | Ambient humi. | 35 to 85%RH, storage: 35 to 85%RH |
| Protection structure | IP20 (IEC standard) | |
| Material | Terminal: polyamide6, Body: modified polyphenylene oxide, Base: polyamide6, polyoxymethylene | |
| Approval | CE cULUS LISTED | |
| Weight \times 1 | Approx. 108g (approx. 75g) | |

※The ARIO digital module is available to connect up to 8 units and the ARIO analog module is available to connect up to 4 units.

● Slim Remote I/O Power Module

| Model | | ARIO-P-F1 | ARIO-P-F2 | ARIO-P-T1 | ARIO-P-T2 |
|-------------------------|--|-----------------------------------|------------------|----------------------------|------------------|
| Input | Voltage | 24VDC \pm 10% (max. 48W) | — | — | — |
| | Max. current | Max. 2,000mA/CH, 2CH/COM | — | — | — |
| Output | Voltage | 24VDC \pm 10% (max. 48W) | — | 24VDC \pm 10% (max. 48W) | — |
| | Max. current | Max. 2,000mA/CH, 6CH/COM | — | Max. 2,000mA/CH, 8CH/COM | — |
| No. of I/O supply power | 24V | 6 | 2 | 8 | 4 |
| | 0V | 2 | 6 | 4 | 8 |
| Installation method | DIN rail mounting | | | | |
| Insulation resistance | 100M Ω (at 500VDC \pm megger) | | | | |
| Environment | Ambient temp. | -10 to 55°C, storage: -25 to 70°C | | | |
| | Ambient humi. | 35 to 85%RH, storage: 35 to 85%RH | | | |
| Protection structure | IP20 (IEC standard) | | | | |
| Material | Terminal: polyamide6, Body: modified polyphenylene oxide, Base: polyamide6, polyoxymethylene | | | | |
| Approval | CE cULUS LISTED | | | | |
| Weight \times 1 | Approx. 108g (approx. 75g) | | | | |

※1. The weight includes packaging. The weight in parenthesis is for unit only.

※Environment resistance is rated at no freezing or condensation.

※For connecting the modules, consider power consumption of the sensors and drivers connected the ARIO power module.

■ Dimensions

(Unit: mm)

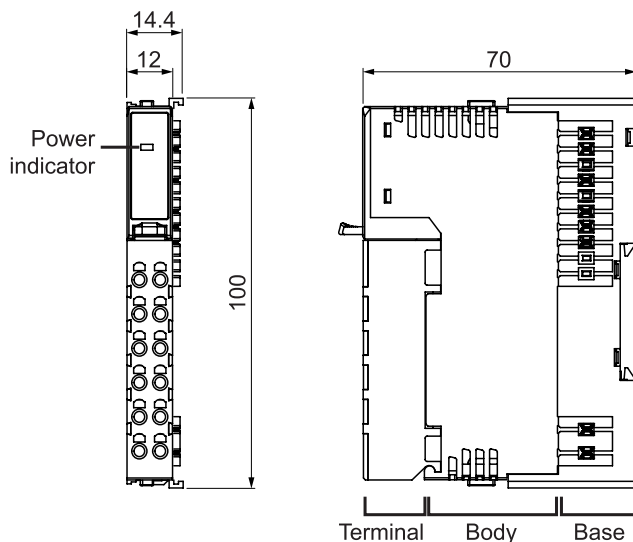

SENSORS

CONTROLLERS

MOTION DEVICES

SOFTWARE

(J) Temperature Controllers

(K) SSRs

(L) Power Controllers

(M) Counters

(N) Timers

(O) Digital Panel Meters

(P) Indicators

(Q) Converters

(R) Digital Display Units

(S) Sensor Controllers

(T) Switching Mode Power Supplies

(U) Recorders

(V) HMIs

(W) Panel PC

(X) Field Network Devices

ARIO Series

General Information

Hot-swap

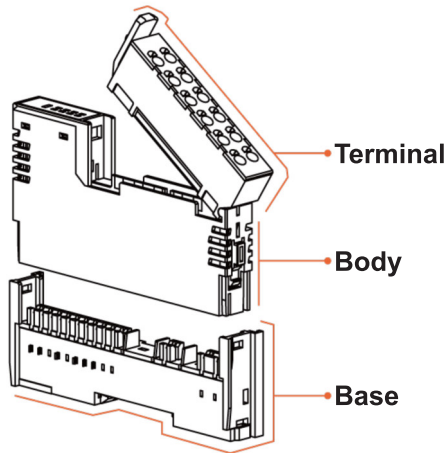

- **Terminal**
: Part of the input and output signal comes out of the product
- **Body**
: Part of the input and output signal controlled of the product
- **Base**
: Part of the communication (ABUS) and power connection between coupler and modules

During the operation of the system, the hardware part (terminal and body) can be replaced and maintenance and setting can be restored automatically. (All modules except coupler and end module support Hot-swap.)

- 1) Terminal / body can be replaced during operation without disassembling the terminal signal line
: Even if the terminal / body of the abnormal I/O module is disconnected from the connected system (Coupler, I/O Module configuration), the other I/O operates normally.
- 2) Diagnostic function: Check removal or connection for terminal or body of abnormal module
- 3) Normal operation of the rearranged module even after removing the body of the module
- 4) Automatic restoration of existing settings when replacing body through backup function of internal ABUS communication

Connecting & Removing Wires

- Connecting
Push the wire ferrule towards direction ① to complete the connection.
- Removing
 - 1) Press and hold the groove on the terminal in direction ② with a non-conductive flat head screwdriver (tip width max. 3mm).
 - 2) Pull and remove the wire towards direction ③.

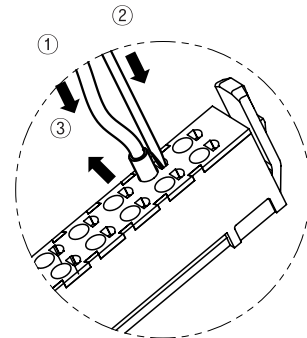

※Use the UL approved wire ferrule.
Use the copper-conductor wire with the temperature class 60°C.

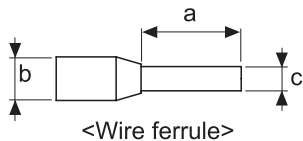

| | a | b | c | Certified spec. |
|-------------|-----------|----------|--------------|-----------------|
| Range | 8 to 12mm | Max. 3mm | 0.6 to 1.3mm | AWG22-16 |
| Recommended | 10mm | | 1mm | AWG18 |

Caution during Use

1. Follow instructions in 'Cautions during Use'. Otherwise, It may cause unexpected accidents.
2. ABUS power and I/O power should be insulated by the individually insulated power device.
3. Power supply should be insulated and limited voltage/current or Class 2, SELV power supply device.
4. Use the rated standard cables and connectors. Do not apply excessive power when connecting or disconnecting the connectors of the product.
5. Keep away from high voltage lines or power lines to prevent inductive noise. In case installing power line and input signal line closely, use line filter or varistor at power line and shielded wire at input signal line.
For stable operation, use shield wire and ferrite core, when wiring communication wire, power wire, or signal wire.
Do not use near the equipment which generates strong magnetic force or high frequency noise.
6. Do not touch the module communication connector part of the base.
7. Do not connect, or remove the base while connected to a power source. For removing the terminal, body or base, do not operate units for a long time without it
8. This unit may be used in the following environments.

| | |
|---------------------|----------------------------|
| ①Indoors | ②Altitude max. 2,000m |
| ③Pollution degree 2 | ④Installation category II) |